

Model 2175 MiniMast™

User Manual

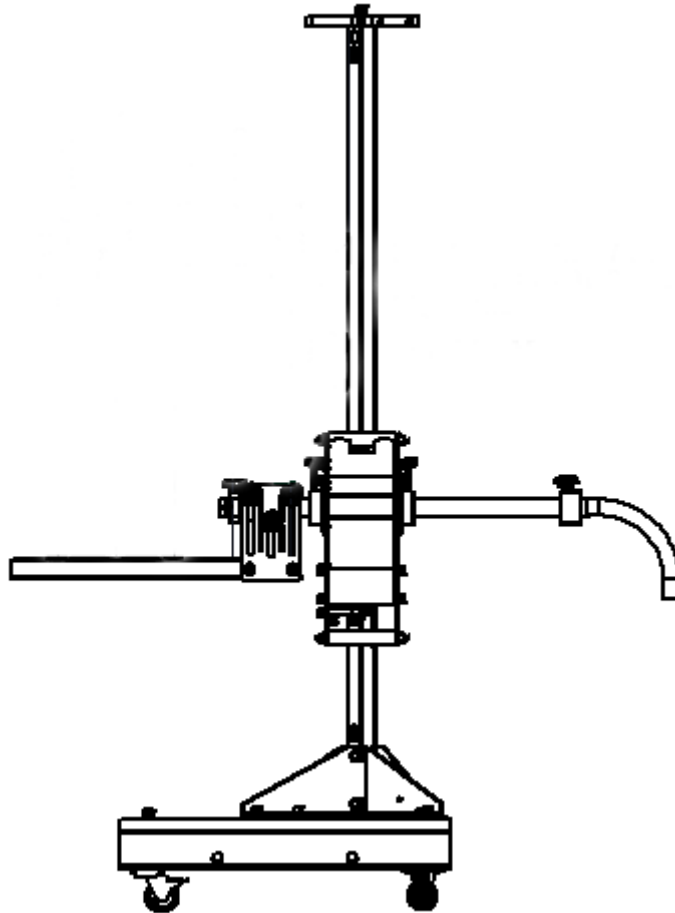

 **ETS·LINDGREN**®
An ESCO Technologies Company

ETS-Lindgren Inc. reserves the right to make changes to any products herein to improve functioning or design. Although the information in this document has been carefully reviewed and is believed to be reliable, ETS-Lindgren does not assume any liability arising out of the application or use of any product or circuit described herein; nor does it convey any license under its patent rights nor the rights of others. All trademarks are the property of their respective owners.

© Copyright 2005–2021 by ETS-Lindgren Inc. All Rights Reserved. No part of this document may be copied by any means without written permission from ETS-Lindgren Inc.

Trademarks used in this document: The *ETS-Lindgren* logo and *MiniMast* are trademarks of ETS-Lindgren Inc.

Revision Record | Model 2175 MiniMast, MANUAL | Part #399770, Rev. E



Revision	Description	Date
A	Initial Release	April, 2005
B	Updates	November, 2005
C	Design updates; rebrand	September, 2008
D	Changed 2090 to EMCenter™	January, 2018
E	Removed IR	December, 2021

Table of Contents

- Notes, Cautions, and Warnings v**
- 1.0 Introduction 7**
 - Standard Configuration 8
 - Optional Items 9
 - EMCenter Modular RF Platform 9
 - ETS-Lindgren Product Information Bulletin 10
- 2.0 Maintenance 11**
 - Maintenance Recommendations 11
 - Routine Check 11
 - Six-Month Check 12
 - Replacement and Optional Parts 12
 - Service Procedures 12
- 3.0 Specifications 13**
 - Electrical Specifications 13
 - Physical Specifications 13
- 4.0 Assembly and Installation 15**
 - Product Assembly 16
 - Electrical Installation 23
 - Connecting the Controller 24
 - Carrier Safety Brake 25
- 5.0 Operation 27**
 - Editing the Controller Configuration Parameters 27
 - MiniMast Encoder Calibration 27
 - Antenna Mounting Instructions 28
 - Pre-Operational Checks 30
 - Start-Up and Safe Shutdown 30
- Appendix A: Drawings 31**
- Appendix B: EC Declaration of Conformity 33**

This page intentionally left blank.

Notes, Cautions, and Warnings

	<p>Note: Denotes helpful information intended to provide tips for better use of the product.</p>
	<p>Caution: Denotes a hazard. Failure to follow instructions could result in minor personal injury and/or property damage. Included text gives proper procedures.</p>
	<p>Warning: Denotes a hazard. Failure to follow instructions could result in SEVERE personal injury and/or property damage. Included text gives proper procedures.</p>



See the ETS-Lindgren *Product Information Bulletin* for safety, regulatory, and other product marking information.

This page intentionally left blank.

1.0 Introduction

The ETS-Lindgren Model 2175 MiniMast™ is a portable, electric-powered mast and platform system designed to be used with the EMCenter™ Modular RF Platform (or next generation ETS-Lindgren controller, if applicable) for EMI compliance testing. The MiniMast is designed for antenna scanning from 1 meter to 4 meters. The mast, carrier, platform, lifting rope, and guying system are non-conductive and non-magnetic. The mast section is constructed of square fiberglass tubing for strength, rigidity, and “weatherability”.



The MiniMast may also be manufactured in custom mast heights. Contact your local sales representative for additional information regarding custom height.

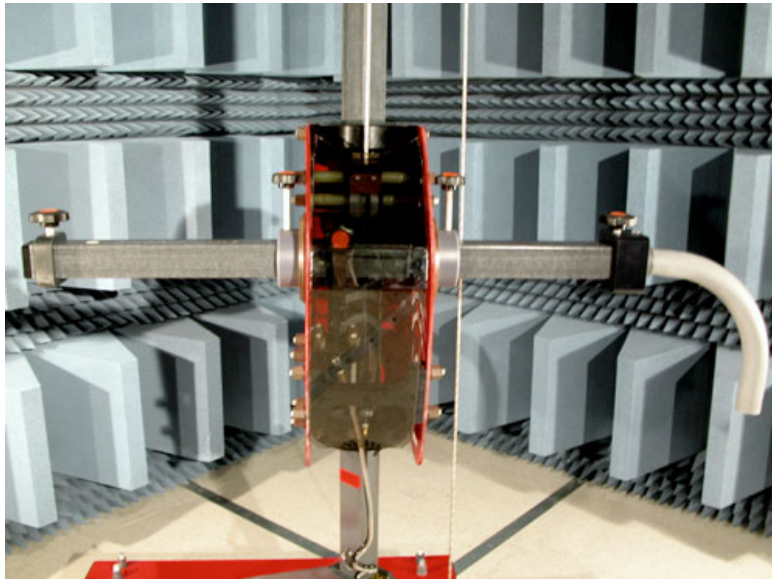

The MiniMast features an offset boom that maintains a constant rotational axis along the centerline when the antenna is rotated from horizontal to vertical polarization. A cable guide at the back end of the boom feeds the coaxial cable to the antenna while maintaining the appropriate bending radius.

For antennas with a stinger mount, the offset boom can be removed. The antenna stinger is then clamped into the mounting block using the hand knob.

The antenna carrier is raised and lowered by a fractional horsepower, electric, variable speed motor. A worm-type gearbox driven by the motor provides the adequate torque needed to raise and lower the carrier and prevents the carrier from back-driving the motor. The motor and associated electronics are contained in a shielded enclosure mounted beneath the platform of the unit. Under command of the controller, the motor typically positions the carrier within one centimeter of the desired location. To prevent over travel of the carrier in either direction of movement, the mast system has integral fiber optic limits. Soft limits may be set within the travel range provided by the mechanical limits using the controller.

The motor base is connected to the controller through a twin fiber optic cable assembly. This fiber optic cable transmits both directional control and position information. Power to the motor base is provided locally to the motor through a detachable, grounded power cable.

A carrier brake is mounted on the carrier assembly. In the event that the carrier is released from the rope suspension, a spring-loaded cam locks the brake into position against the mast and locks the carrier so that further vertical movement is restricted.

CAUTION

The carrier brake is intended to provide some protection to the carrier and the antenna; it is not a fail-safe brake for protection to personnel. Personnel operating this equipment should be instructed to stay clear of the carrier and boom at all times whether or not the carrier is moving.

Polypropylene braided rope guy lines are provided for installations requiring the mast to be guyed and must be firmly anchored for vertical stability. Use of the guy lines is recommended in all applications to provide maximum stability.

Standard Configuration

- Motor, 220 VAC, nominal
- Input frequency 50 or 60 Hz
- Tower platform casters for movement of the unit
- Offset antenna mount
- Stinger antenna mount
- 10-meter fiber optic control cable for inside chamber

- 3-meter fiber optic control cable for connection to EMCenter Modular RF Platform (or next generation ETS-Lindgren controller, if applicable) outside chamber
- Two ST-to-ST bulkhead feedthroughs provide a means to penetrate a shield wall and maintain the integrity of the shielded enclosure
- Air polarization (adjustable speed)

Optional Items

- **EMCenter Modular RF Platform** (or next generation ETS-Lindgren controller, if applicable): This controller provides control for two separate devices (for example, towers and turntables) in any combination, plus the control of two auxiliary devices through a fiber optic interface. The unit includes a GPIB connection and is compatible with most popular EMI measurement software.
- **Universal Antenna Mount**: This option is a versatile and sturdy mount for most common antennas.
- **Additional Fiber Optic Cable**: Various lengths of fiber optic cable are available by custom order.

EMCenter Modular RF Platform

The ETS-Lindgren EMCenter™ Modular RF Platform (with EMControl™ Positioner Controller Plug-In Card) may be used to control the Model 2175 MiniMast™. For information on connecting and using the EMCenter, see the *EMCenter Modular RF Platform User Manual*, available for download at ets-lindgren.com.

The EMCenter replaces the 2090 Controller, which has been discontinued. The basic controller configuration is an EMCenter with an EMControl card. This assembly is ETS part number 125241.

Check ets-lindgren.com or contact ETS-Lindgren to ensure that your EMCenter, the EMControl card, the backplane, and display all have the current firmware versions.

EMCenter: V5.21 (or later)

EMControl (7006-001) Card: V2.5.6 (or later)

Backplane: V2.3.0 (or later)

Display: V1.4.10 (or later)

The EMCenter is also expandable with a variety of additional options available. Please contact ETS-Lindgren with any questions.



Note: If you are unfamiliar with the operation of the EMCenter, see the manual, available for download from ets-lindgren.com.

The EMCenter replaces the 2090 Controller, which has been discontinued.

The 2090 requires firmware revision V 3.21 or higher. It is available for download at ets-lindgren.com and requires the program Flash Upgrade Wizard V 4.0 (also available at ets-lindgren.com).

ETS-Lindgren Product Information Bulletin

See the ETS-Lindgren *Product Information Bulletin* included with your shipment for the following:

- Safety, regulatory, and other product marking information
- Steps to receive your shipment
- Steps to return a component for service
- ETS Lindgren calibration service
- ETS Lindgren contact information

2.0 Maintenance

WARNING

Before performing any maintenance, follow the safety information in the ETS-Lindgren *Product Information Bulletin* included with your shipment. Warranty may be void if maintenance is performed incorrectly.

Maintenance of the Model 2175 MiniMast™ is limited to external components such as cables or connectors. If you have any questions concerning maintenance, contact ETS-Lindgren Customer Service.

Maintenance Recommendations

Regular maintenance will prolong the service of your mast assembly. If excessive wear or damage is found during any of the recommended checks, the system must be taken out of service and repaired before proceeding. Pneumatic tubing that appears to be brittle and worn from the effects of UV radiation and inclement weather should be replaced. Lubricant may be purchased from ETS-Lindgren; contact the Sales Department at +1-512-531-6400 and request item #890437.

CAUTION

Before performing any maintenance, disconnect the unit and turn off power.

ROUTINE CHECK

- Prior to beginning normal operation of the mast, check the mast and lift system for any signs of damage or excessive wear.
- Checks the lift rope for excessive wear.
- Check the mast and carrier for any signs of damage or excessive wear.
- Check the guy line(s) to ensure safe and secure and check for excessive wear.
- Verify the height readout of the controller and the physical position of the mast are the same.
- Verify the antenna is secure.
- Check routing of all cables to make sure they do not interfere with the operation of the mast.

SIX-MONTH CHECK

- Check the lift rope and guy line for signs of wear.
- Inspect the components and tubing of the pneumatic polarization mechanism for signs of corrosion, excessive moisture, and wear.
- Lubricate the air cylinder O-rings to prevent excessive wear.
- Check all cabling to the motor base for frayed and worn insulation.

Replacement and Optional Parts

See the drawings located in the back pocket of this manual for the part numbers to order replacement or optional parts for the MiniMast.

Service Procedures

For the steps to return a system or system component to ETS-Lindgren for service, see the *Product Information Bulletin* included with your shipment.

3.0 Specifications

Electrical Specifications

Nominal AC Voltage	220 VAC
Input Frequency	50/60 Hz
Current Rating	10 Amp service
Phase	Single

Physical Specifications

Base Dimensions	0.90 m x 0.90 m 2.95 ft x 2.95 ft
Weight	81.2 kg (179.0 lb)
Overall Height	4.61 m (15.1 ft)
Mast Height	Nominal 4.5 meters
Scan Range	4 meters standard Custom height may be specified upon placement of order
Required Air Pressure	60-80 psi (410-550 kPa)
Carrier Load Rating	Not to exceed 18 kg (40 ft lb)
Maximum Loading	10 kg (22 lb) See <i>Operation</i> on page 27 for additional information

This page intentionally left blank.

4.0 Assembly and Installation

WARNING

Before connecting any components, follow the safety information in the ETS-Lindgren *Product Information Bulletin* included with your shipment.

The Model 2175 MiniMast™ is shipped partially assembled; the assembly process will take approximately one hour. Ensure that a clear area is available to unpack and assemble the MiniMast. Prior to starting the assembly process, open the shipping container and check all parts for any shipping damage.



Do not discard any packing material until the MiniMast is fully installed and operation. During this assembly procedure, refer to the illustrations provided for each step.

Tools needed for assembly (included with shipment):

- Adjustable open-end wrench
- Phillips head #2 screwdriver



Figure 1: Tools shipped with MiniMast

Product Assembly

1. Attaching the motor is the first step of the assembly process. Locate the motor in the packaging under the positioner base. Lay the motor with the winch drum facing the direction of the slot provided in the base. Roll the platform over the top of the motor and find the brackets under the platform that pin the motor into position.



Tabs on motor slide between the brackets on the platform.

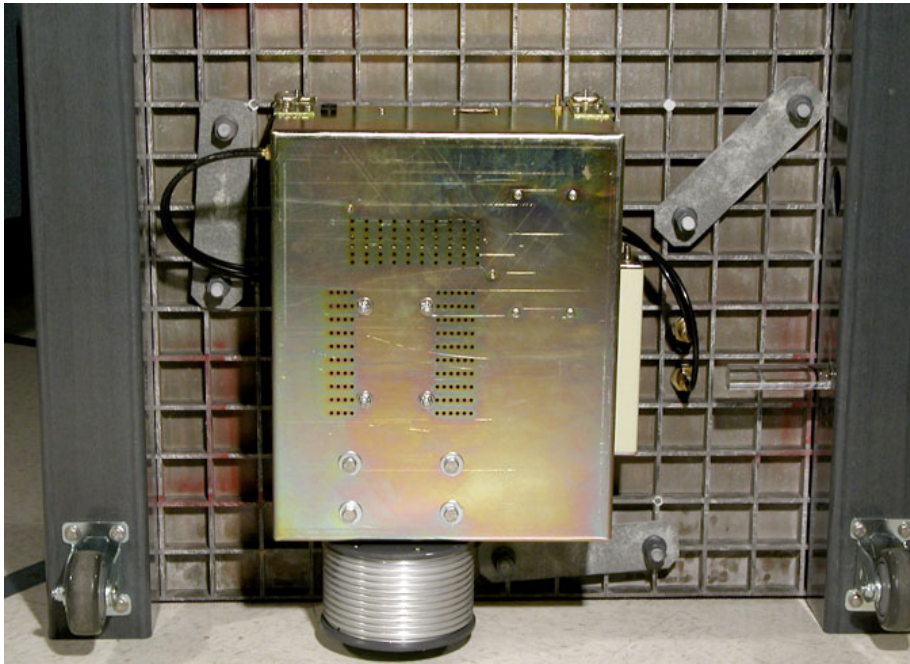

Figure 2: Motor attached to bottom of MiniMast

2. Lift slightly on the motor and insert the pins provided to secure the motor in position. Once pinned into position, the platform and motor together may be placed on one side to connect the air hoses from the platform to the motor base. After the air hoses are connected lay the positioner platform back into position with the casters on the floor.

- Continuing with the assembly, insert the mast into the support angles on the platform. An axle bushing with stud and nuts for securing in place is on the platform. Carefully remove the fiber optic cable packed into the lower end of the mast and straighten the leads. Insert the mast between the two angle supports in approximately the correct position. Insert the mast axle. After the axle is in place, route the fiber optic limit cables through the fiber optic hole provided in the platform.



Do not damage the fiber optic cable during this step. Make sure it is out of the way when inserting the mast axle through the mast.

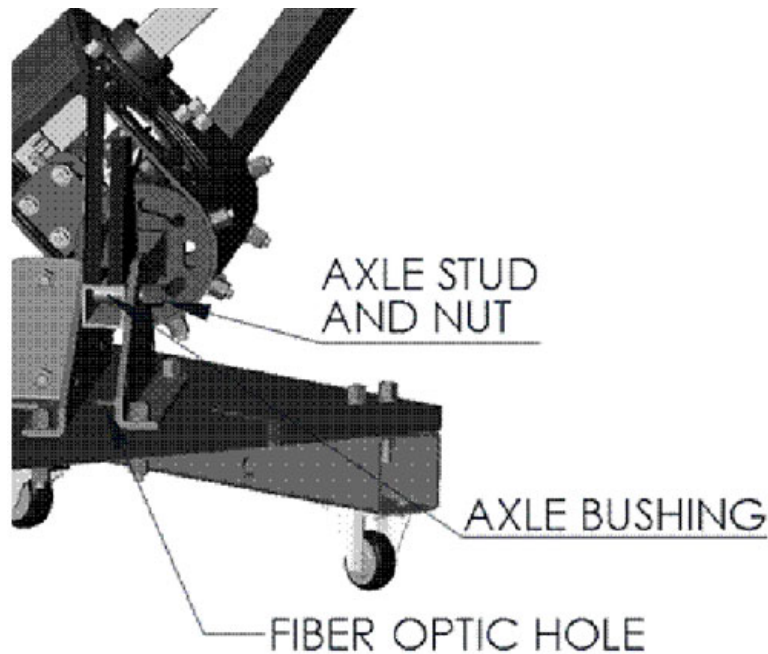

Figure 3: Fiber Optic Placement

- Place the carrier and top cap into the position shown on the mast. Verify that the carrier brake engages the corner of the mast and all components are oriented as shown in the following picture. The top cap of the mast bolts into place with an axle nut and a threaded fiberglass stud and nut combination. Securely tighten the nut and stud to secure the top cap. The stud should be flush with the nut when tightened in the proper position. Uncoil the guy ropes and let them hang unobstructed.

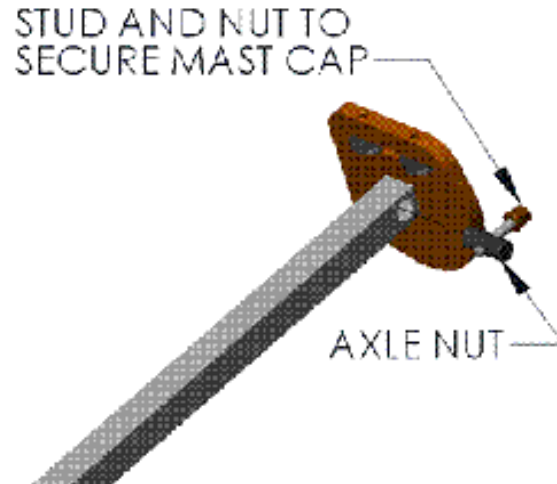

Figure 4: Securing the Mast Cap

5. Unwind the rope from the winch drum and feed it over the pulleys so that the free end lines up with the clamp on the carrier brake assembly. Feed the rope through the clamp on the brake assembly and tighten clamp nuts hand tight. Further adjustment will be necessary once the mast is completely assembled.

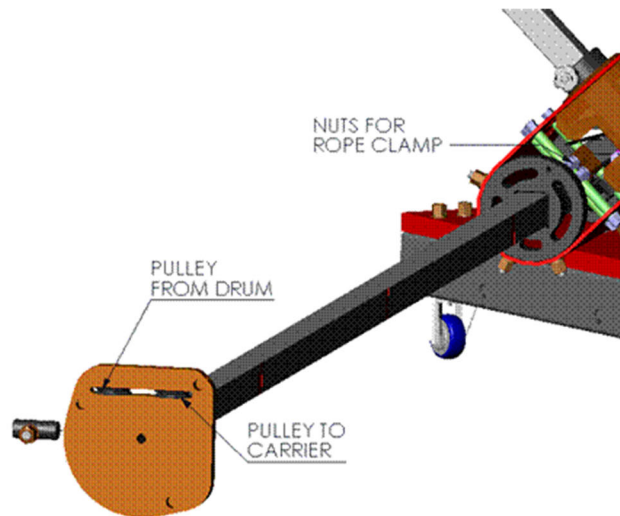

Figure 5: Pulley Location

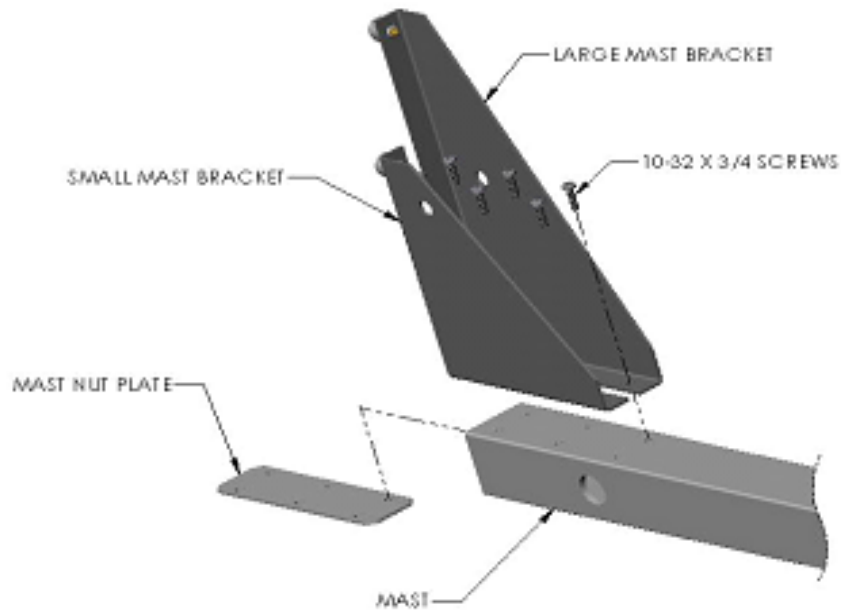

Figure 6: Screw Placement

6. The mast brackets should be installed according to the orientation shown in previous illustrations. Using the #2 Phillips screwdriver provided, tighten the screws through the large and small mast brackets through the mast and into the nut plate that is already fitted with inserts.
7. Engage the brakes on the swivel casters of the platform so that they will not roll. Carefully raise the mast to a vertical position and insert the lock pin provided to hold it in place.



Do not attempt the next portion of the assembly with less than two people.

Care should be taken to keep the carrier from contacting the platform during this procedure so that it cannot damage the platform.

8. Leaving approximately one turn of rope on the winch drum, pull the hoisting rope tight through the clamp block on the brake. Once the clamp is fully tightened onto the rope, tie a loose half-knot on the mast side of the clamp to make sure the rope does not slip back through the clamp. Once this is accomplished, wind the excess rope around the clamp portion of the brake so that the brake still functions correctly and the rope does not interfere with the carrier working properly.
9. Attach the free end of the guy lines to anchors located on the ground plane or within the chamber.



Outdoor applications require guying to stabilize the mast against wind. For outdoor applications, engage the lock on the swivel casters at this time.

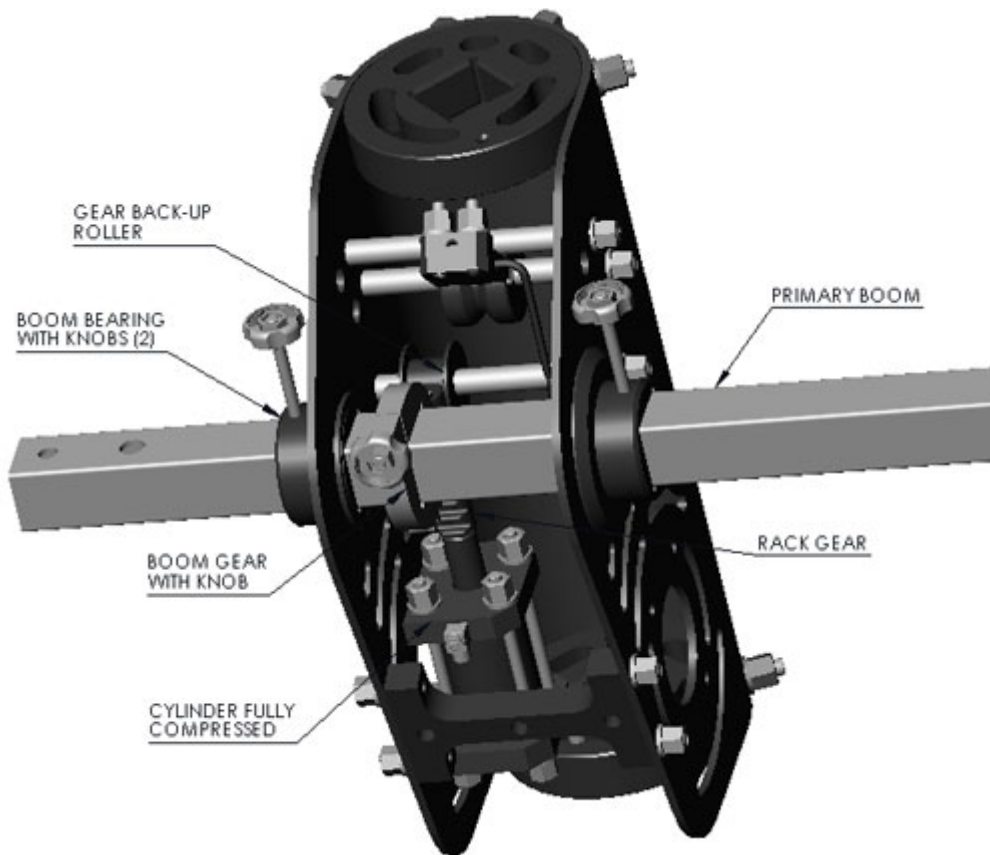
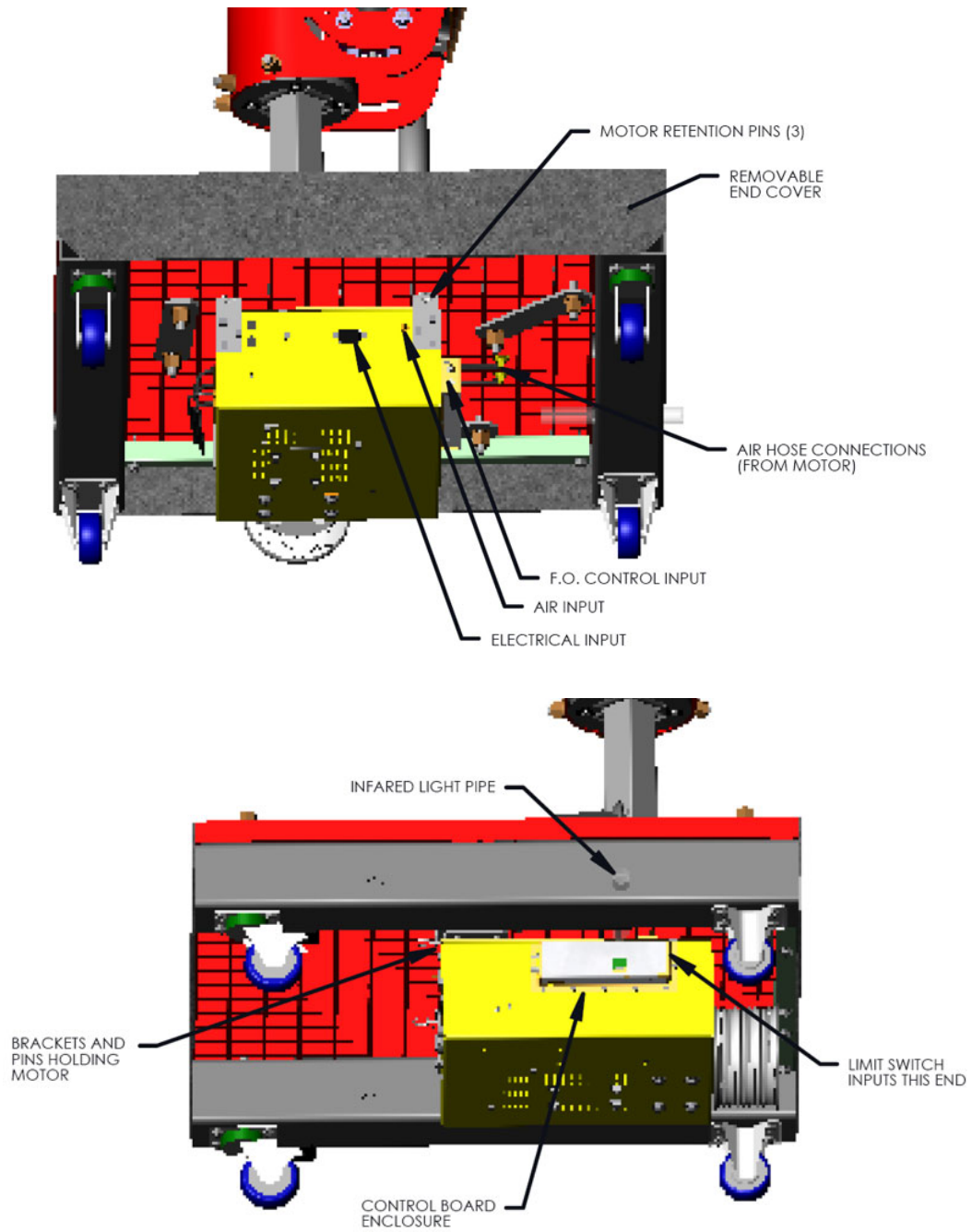

Figure 7: Boom Placement

10. Pull the coiled hose out of the carrier and insert the primary boom as pictured into the carrier. Note the position of the knobs on the boom gear and on the boom bearings. The gear back-up roller should be directly behind the rack gear and the cylinder should be in a fully compressed state. Incorrect horizontal and vertical polarization angles will result if the cylinder is not fully compressed. Once the primary boom is locked in place, install the offset boom and the coaxial cable strain relief.

LOCATION OF CONNECTIONS



LOCATION OF CONNECTIONS, CONTINUED

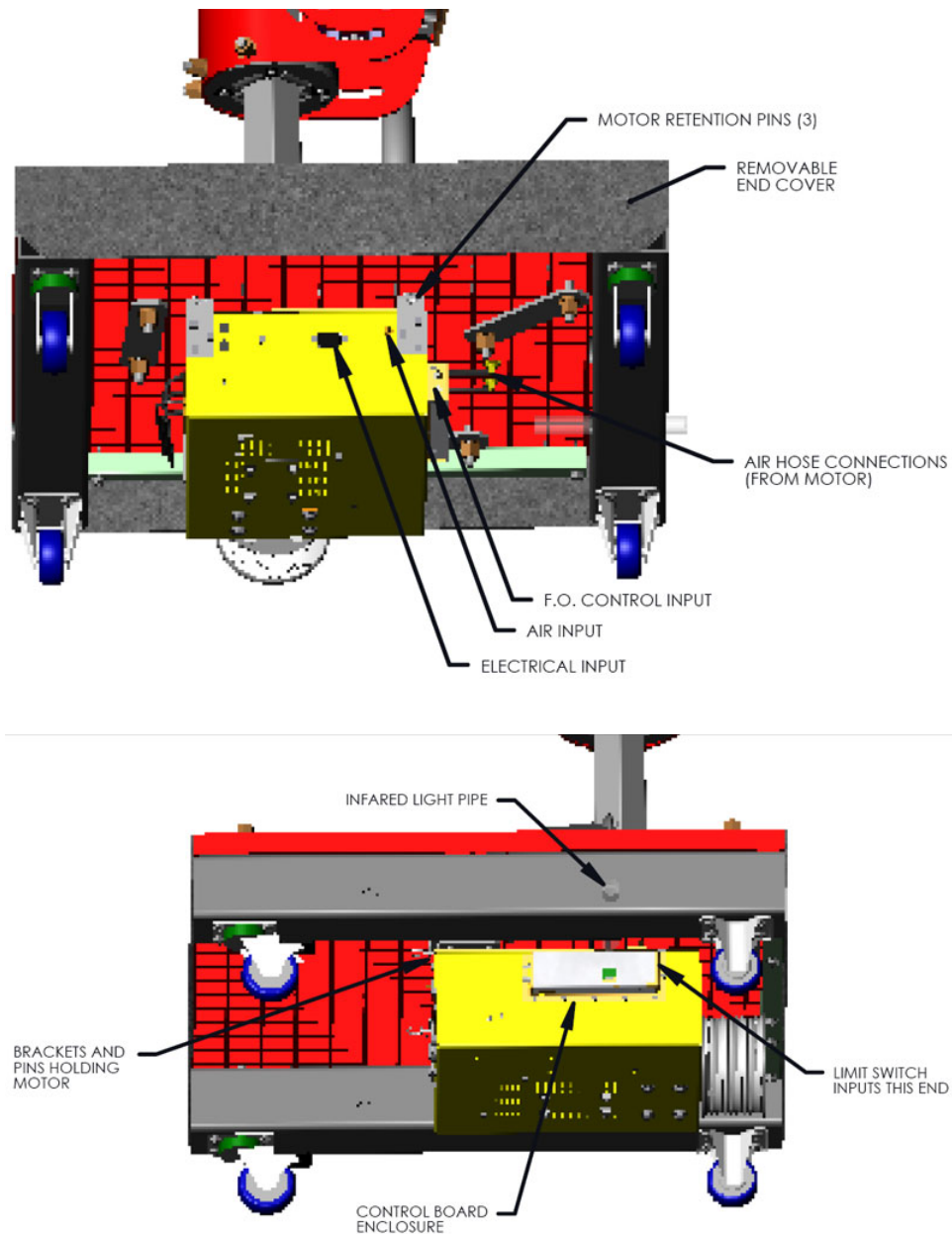

Figure 8: Location of Connections

11. Coiled hoses that were located inside the carrier should be connected to the fittings on the platform for the polarization to become operable. All connections to the motor base should be completed at this time including fiber optic limits and control lines, along with compressed air and electrical power. Route all connections through the connection entry on the platform tube so they will exit through the connection exit. Install the platform end covers by positioning and applying pressure to secure them in place. Check to see that the controller reads horizontal polarization.

12. Slightly engage the air lines onto the fittings and note the position of the boom. Energize the air line supply to the motor base. If the boom is in horizontal polarization (holes in the boom are on top), fully engage the hoses onto the fittings provided. If the boom is in vertical polarization, turn the air off and reverse the air lines and then fully engage them on the fittings provided in the platform.



Air line pressure should be between 60–80 psi (4.14–5.52 bar). Do not exceed 80 psi (5.52 bar).

CAUTION

Keep hands away from any portion of the carrier while performing this task. Failure to do so may result in personal injury.

WARNING

Do not perform any service on the carrier with the air lines energized.

13. When the MiniMast is in the position where testing will occur, lock the brakes provided on the swivel casters to prevent movement of the platform.

Electrical Installation

The motor base is provided with a three-conductor AC power cord that is approximately 2.45m (8 ft) long. Power to the motor base is 220 VAC. The motor base should be wired to a circuit capable of providing 10 amps of service. The power cord is to be terminated into an outlet near the motor base. The power cord is suitable for portable or indoor applications without modification. Ideally, the power cord would exit the motor base and terminate into an outlet with as short a cord as possible as the start and stop actions of the motor base create a small amount of RF noise through the power cord.



If this equipment is to be operated outdoors, precautions must be taken to protect the MiniMast from the weather. In the event that modifications are required, the installation should be compliant with all local and national electrical safety codes.

CAUTION

As with all electrical devices, disconnect the power prior to servicing the equipment.

A fuse is mounted on the side of the motor enclosure. This fuse provides protection for the motor and the associated electronics. An additional fuse provides protection for the DC power supply inside the motor base.

The branch circuit supplying power to the motor base should be protected from excess current according to local electrical codes. Whenever possible the motor should be powered from a separate branch circuit of adequate current capacity to keep voltage drop to a minimum during startup and running.

Check that the conductor size is adequate for the motor load and the distance from the mains source. Improperly sized conductors will lead to a high voltage drop in the power conductors and cause reduced starting torque and premature motor failure. For longer runs, increase the wire size in accordance with the wire selection guide shown below. When considering what gauge of wire to use, never use smaller than 14 AWG for any installation.

Length of wire @220V	0–15.24 m (0–50 ft)	15.24–30.48 m (50–100 ft)	30.45–60.96 m (100–200 ft)
Wire gauge required	14 AWG	14 AWG	14 AWG

Connecting the Controller



Note: If you are unfamiliar with the operation of the EMCenter, see the manual, available for download from ets-lindgren.com.

The EMCenter replaces the 2090 Controller, which has been discontinued.

The 2090 requires firmware revision V 3.21 or higher. It is available for download at ets-lindgren.com and requires the program Flash Upgrade Wizard V 4.0 (also available at ets-lindgren.com).

Any combination of devices may be connected to the two device interface ports located on the rear panel of the EMCenter Modular RF Platform (or next generation ETS-Lindgren controller, if applicable). The default settings are for a tower connected to the Device 1 interface port and a turntable connected to the Device 2 port.



Fiber optic cabling for each device should not be allowed to hang unsupported from the rear panel of the controller. The fibers and connectors are easily broken if twisted or bent. Keep the fiber optic cables as straight as possible from the connector to the protective sheath.

Device connection is accomplished with a dual fiber optic cable included with the device. This cable terminates into two ST connectors that are identical at both ends. The cable is symmetrical; either end can be connected to the controller. A fiber optic cable that connects to the IN port of a controller should, at the other end, be connected to the OUT port of the motor base. A fiber optic cable connected to the OUT port of the controller should, at the other end, be connected to the IN port of the motor base.



The fiber optic mechanical limits must be set before the carrier is able to move.

Carrier Safety Brake

A safety brake is mounted on the carrier assembly. In the event that the carrier is released from the rope suspension, a spring-loaded cam jams the brake into position against the mast and slows the vertical movement of the carrier.

CAUTION

The safety brake is not intended to completely restrict movement of the carrier. Always exercise extreme caution when the safety brake is engaged.

To release the carrier safety brake, support the carrier and release the brake roller. Slide the carrier down to the base of the mast. Replace the carrier rope if necessary. Reset the current position using the controller before resuming use of the mast.

This page intentionally left blank.

5.0 Operation

WARNING

Before connecting any components, follow the safety information in the ETS-Lindgren *Product Information Bulletin* included with your shipment.



Note: If you are unfamiliar with the operation of the EMCenter, see the manual, available for download from ets-lindgren.com.

The EMCenter replaces the 2090 Controller, which has been discontinued.

The 2090 requires firmware revision V 3.21 or higher. It is available for download at ets-lindgren.com and requires the program Flash Upgrade Wizard V 4.0 (also available at ets-lindgren.com).

Editing the Controller Configuration Parameters

See the EMCenter Modular RF Platform (or next generation ETS-Lindgren controller, if applicable) manual, available for download from ets-lindgren.com, for steps to edit the configuration parameters.

MiniMast Encoder Calibration

The display symbol *C* refers to the encoder calibration parameter. This setting is used to convert the encoder count values returned from a motor base into the corresponding centimeter or degree position reading. For towers, the number represents the number of encoder counts per meter. Using this parameter, a variety of standard, retrofit, and custom devices can be used. The setting for the Model 2175 MiniMast™ is **2000**.

If the given value does not appear to work correctly, the encoder calibration value can be determined using the following procedure:

1. Set the encoder calibration value to **1000**.
2. Ensure that the MiniMast is positioned to allow at least one meter of travel in the upward direction at an easily measurable height, then set the current position reading to **000.0**.



You must adjust the lower limit setting to allow at least one meter of travel.

3. Using the STEP keys of the controller, adjust the height of the carrier until it is one meter above the start point.
4. Record the reading of the display, ignoring the decimal point (for example, **200.0** would be **2000**). This is the encoder calibration value.



If the value is below 1000, the resolution of the encoder is low and the controller will not provide 0.1 cm resolution, even though the display shows that digit. If the value has gone past 9999, the encoder has too many counts per meter and the controller cannot correct for it. In this case, contact ETS-Lindgren for assistance.

5. Enter this value for the encoder calibration value and reset the limits and position information.
6. Test the MiniMast by moving it to a known distance and comparing the display to the measured distance traveled. It may be necessary to adjust the encoder calibration value up or down slightly depending on the result.

Antenna Mounting Instructions

Antennas may be mounted to the assembly using either the 7/8–14 thread which is common on ETS-Lindgren brand antennas, or the 1/4–20 thread which is another common size. The antenna should be mounted on the boom as close to the carrier as possible. Insert the mounting knobs through the holes on the boom and align the mounting holes on the antenna with the threaded end of the mounting knobs. Secure the antenna in place by tightening the threaded knobs into the receptacle mounting holes on the antenna.

Antennas may also be mounted using the stinger mount adapter included with the assembly.

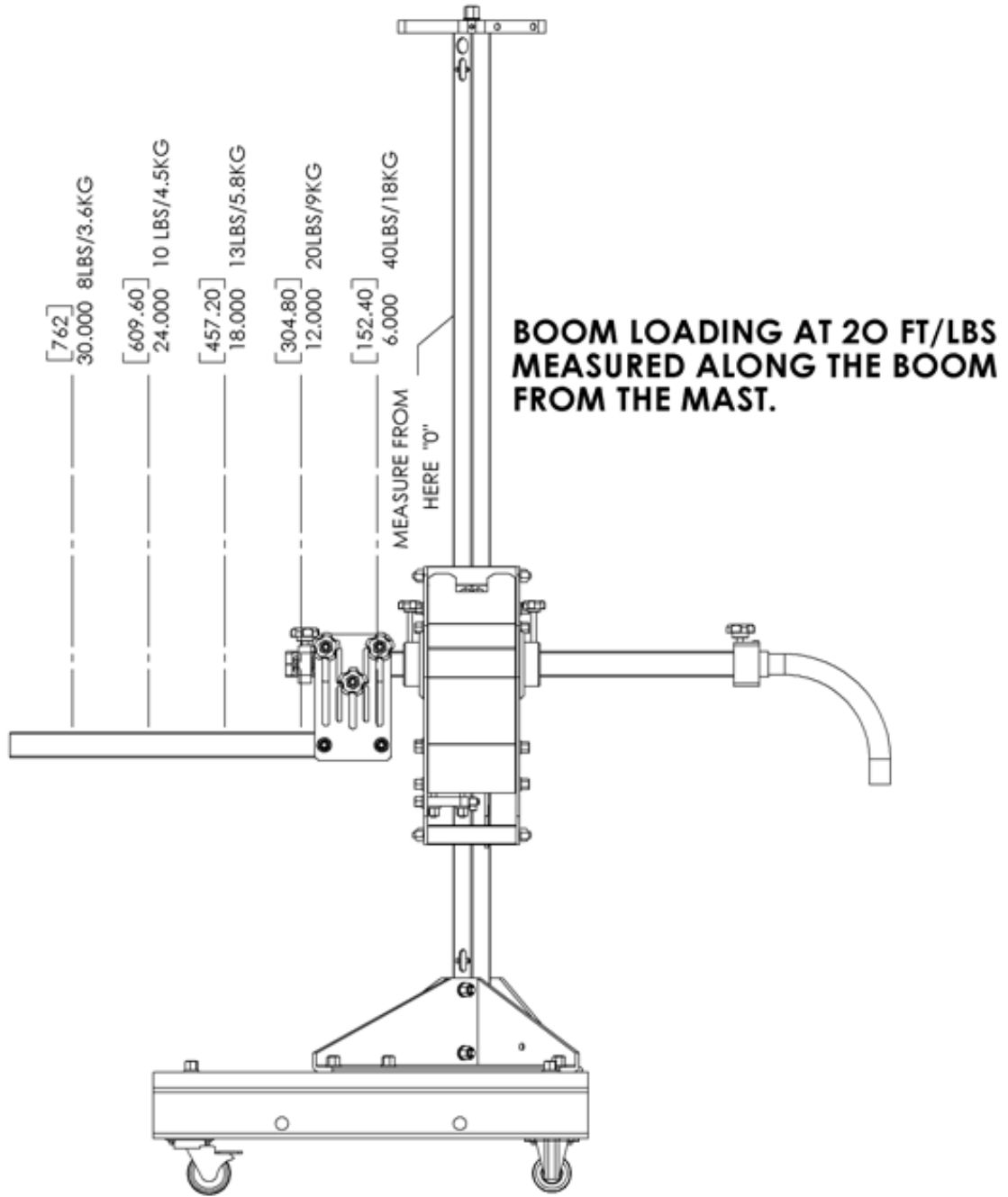

Figure 9: Boom Load Limitations

Pre-Operational Checks

- Verify that the power lines are connected to the motor base for the MiniMast, controller, and any other equipment that will be used to test.
- Verify the fiber optic cables are connected to the motor base.
- Verify the limit fibers are connected to the motor base.
- Verify the antenna connected to the boom is securely mounted in place.
- Connect the feed cable to the antenna.
- Verify the load of the antenna is within the operating specifications.

Start-Up and Safe Shutdown

After completing the pre-operational checks, the controller may be turned on by pressing the power button. See the EMCenter Modular RF Platform (or next generation ETS-Lindgren controller, if applicable) manual, available for download from ets-lindgren.com, for operating instructions.

Prior to shutting the MiniMast down, move the carrier to an accessible height for the removal of the antenna. Make sure the unit has come to a complete stop. Press the power button on the controller to turn it off. Finally, remove power from the MiniMast.



Note: If you are unfamiliar with the operation of the EMCenter, see the manual, available for download from ets-lindgren.com.

The EMCenter replaces the 2090 Controller, which has been discontinued.

The 2090 requires firmware revision V 3.21 or higher. It is available for download at ets-lindgren.com and requires the program Flash Upgrade Wizard V 4.0 (also available at ets-lindgren.com).

Appendix B: EC Declaration of Conformity



Declaration of Conformity

We, ETS-Lindgren, L.P., 1301 Arrow Point Drive, Cedar Park, TX, 78613, USA, declare under sole responsibility that the:

Model/Part Number: 2175

Model/Part Name: 2175 Antenna Mast with 2175 style motor base

Date of Declaration: 01 May, 2005

to which this declaration relates, meets the requirements and is in conformity with the relevant EC Directives listed below using the relevant section(s) of the following EC harmonized standards and other normative documents;

Applicable Directive(s):

Low Voltage Directive (LVD), 73/23/EEC and its amending directives

Electromagnetic Compatibility Directive (EMC), 2004/108/EC and its amending directives

Applicable harmonized standard(s) and/or normative document(s):

EN 55011: Electromagnetic emissions requirements for Industrial, Scientific and Medical (ISM) Equipment

EN 61000-4-11:1994 Electromagnetic compatibility Part 4. Testing and measurement techniques section 11: Voltage dips, short interruptions and voltage variations immunity tests

EN 61000-4-2:1995 Electromagnetic compatibility (EMC) – Part 4-2: Testing and measurement techniques - Electrostatic discharge immunity test

EN 61000-4-3:1997 Electromagnetic compatibility for Electrical and Electronic Equipment. Part 3: Immunity to radiated, radio frequency, electromagnetic fields

EN 61000-4-4:1995 Electromagnetic compatibility for industrial process measurement and control equipment, Part 4: Electrical fast transient/burst requirements

EN 61000-4-5:1995 Electromagnetic compatibility for electrical and electronic equipment, Part 5: Surge immunity requirements

EN 61010-1: Safety requirements for electrical equipment for measurement, control, and laboratory use

ENV 50204:1996 Radiated electromagnetic fields from digital radio telephones - Immunity test

Authorized Signatories:



ETS-Lindgren, L.P.
Bryan Sayler, General Manager

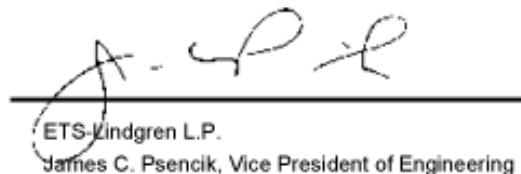

ETS-Lindgren L.P.
James C. Psencik, Vice President of Engineering

The authorizing signatures on this Declaration of Conformity document authorizes ETS-Lindgren, L.P. to affix the CE mark to the indicated product. CE marks placed on these products will be distinct and visible. Other marks or inscriptions liable to be mistaken with the CE mark will not be affixed to these products.

ETS-Lindgren, L.P. has ensured that technical documentation shall remain available on premises for inspection and validation purposes for a period ending at least 10 years after the last product has been manufactured.